

Intelligent controller for stairs - Version 5-20 points of light

Specification:

Supply voltage: 8-15V DC. Typically 12V DC.

Power consumption by the same controller: 20mA.

Power consumption by the same controller for supply voltage - 12V 0.25 W.

Current Load (Intensity): to 1A per channel (step).

Ambient temperature: 5-35° C.

Description of the controller:

- Keys (DIP) "M", "+", "-", "S" - keys for programming
 - PS - input light is constant (after short circuit) - light all the points of light) a permanent light
 - PD - sensor input short circuit (NO) up - down
 - PG - sensor input - short circuit (NO) down - up
 - Inputs 1 - 20 - Inputs other channels
 - "-12V" - input "-" Power DC
 - "12 V" - input "+" Power DC
-

Algorithm (the controller functions):

- Traffic control on the stairs (you go - from "up" to "down")
 - Traffic control on the stairs (you go - from "down" to "up")
 - Traffic control with mutual traffic on the stairs (one person from "up" the second person from "down")
 - Mode "step by step" or "smooth lighting"
 - Regulation lighting time of the light (from 0.25 seconds to 5 seconds)
 - Regulation blanking time points of light (from 10 seconds to 3 minutes)
 - Different modes of operation in standby mode
- the mode "everything is off"
- the mode - the extreme points of light shine
- the mode - all the points of light shine
- Regulation the brightness of light points in standby mode
 - Permanent light (with using PS)
 - Supports traffic from the landing (with using PS - a permanent light)

Turn on channel by channel. Turning off the channel by channel. Before we come to the end result and the second detector work will result in the opposite direction and will meet two effects on the way (the driver finds a person from the opposite direction). If it comes to the end result and work a

second detector, the controller recognizes that a person leaves the stairs and it will be a signal to fade in the same direction as the lit (one was on the stairs, entered and left).

Programming

Entering Programming Mode:

1. Turn off the 12V DC power supply to the controller
2. Press and keep the microswitch "M"
3. Turn the power on 12V DC controller
4. Entering the programming mode signals LED blink three times from 1 to 5
5. The controller goes into programming mode first step is to program number of stairs (light points)

Programming the number of steps (points of light) - no lights red LED

1. The default number is 5 points of light
2. The number of selected points of light is indicated by red LED no. 2 (how many times as red LED no 2 blinks - so is the set - points of light (stairs))
3. After entering the programming mode use buttons (microswitches) "+" and "-" to select the expected number of points of light (stairs). Each press of the button causes the LED sequence, wait for it to complete before the next press of a button (DIP)
4. Press button (microswitch) "S" to confirm quantity stairs (light points)
5. After pressing the "S" - go into the programming mode operation (step by step or smooth lighting)

Programming working mode (step by step or smooth lighting) – lighting red LED No. 5

1. The default mode is smooth
2. Pressing the (DIP) "+" to select the mode - step by step (visual LED 1)
3. Pressing the (DIP) "-" to select the mode – smooth lighting” (visual LED 1)
4. Press button (microswitch) "S" to confirm operation
5. After pressing the "S" go into the programming mode speed light (lighting) stairs (points of light)

Programming the speed of light (lighting) stairs (of the light) –lighting red LED No. 4

1. The user has a choice of 20 times light (lighting) from 0.25 seconds to 5 seconds - pressing any key "+" or "-" to change the setting by 0.25 seconds
2. Pressing the (DIP) "+" extends the light (lighting) stairs (visual LED 1)
3. Pressing the (DIP) "-" reduces light (lighting) stairs (visual LED 1)
4. Press button (microswitch) "S" to confirm the speed of light (lighting) stairs (of the light)
5. After pressing the "S" go into the programming mode staircase lighting time (points of light) after passing by user

Programming the staircase lighting (light spots) after passing by user – lighting LEDs no. 4 and 5

1. The default is 10 seconds. You can change this value in the range from 10 seconds to 3 minutes. The signaling is by LED no. 1 every blink it is 10 seconds (you can change from 1 to 18 - blinks)
2. Pressing the (DIP) "+" increases the lighting time (lighting) steps after passing the user (visual LED 1)
3. Pressing the (DIP) "-" reduces lighting (lighting) steps after passing the user (visual LED 1)
4. Press button (microswitch) "S" to confirm the staircase lighting time (points of light) after passing by user
5. After pressing the "S" go into the programming – standby mode (no one moves up the stairs)

Programming the controller standby mode (no one moves up the stairs) – lighting LED no. 3

1. The controller is equipped with three modes of operation in standby mode (the default mode set "a") (LED signaling 1)
 - a. not light any light points (one blink LED 1)
 - b. lights are on all the points of light (the power set of the light source) (two blinking LEDs No. 1)
 - c. lights are extreme points of light (the power set of the light source) (three LEDs blink 1)
2. Pressing the (DIP) "+" or "-" changes the standby mode
3. After pressing the "S" move on:
 - a. a programming mode brightness light points in standby mode (if you choose option "b" or "c").
 - b. at the end of the programming if you selected "and" - should then finish programming by pressing (DIP) 'M' ". Saving to memory is signaled blink three times, all red LEDs from 1 to 5

Programming brightness light points in standby mode – lighting LEDs no. 3 and 5

1. Visualization brightness light points in standby mode is done by LED 1
2. Pressing the (DIP) "+" brightens spot light (LED visualization No. 1)
3. Pressing the (DIP) "-" dim spot light (LED visualization No. 1)
4. Press button (microswitch) "S" to confirm the brightness of light points in standby mode
5. Complete set of programs will be signaled by a single blink all the red LEDs from 1 to 5
6. Save your settings and exit programming by pressing key (DIP) "M". Saving to memory is signaled blink three times, all red LEDs from 1 to 5

Connecting to the montions sensors RESTAN

Connected properly

- Terminal 1 - (- 12V)
- Terminal 2 - (+ 12V)
- Terminal 3 (PG or PD of controller)
- Terminal 4 – (PG or PD of controller)

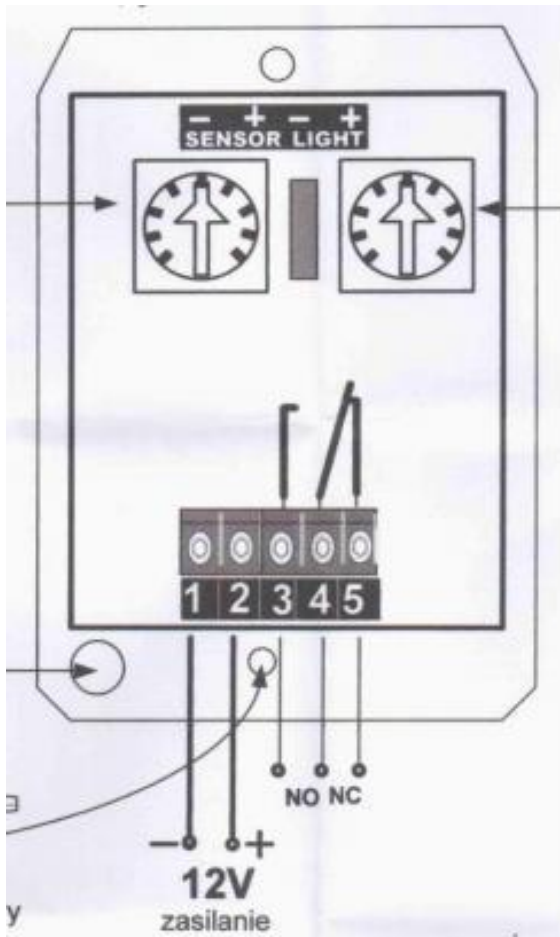

Motion Sensor - Miniature - 12V/15A – integrable

Description – Application

Sensor - 12V/15A - with a miniature lens is designed for installation inside buildings. It can be used for automatic switching of lighting with intelligent controllers, universal design (mechanical - electric) allows the use of the sensor as an independent actuator connector.

Specifications

Power supply	12V DC
Max load current	15A
Detection angle	20 degrees
Adjusting the back-up time	Smooth adjustment - from impulse - up to 5 minutes
Detection range	Smooth adjustment - 0.2 m - up to 3m

Functions

- Control measures according to ambient light intensity
- Adjusting the back-up time
- Adjusting the detection range

Setting - start - Sensor

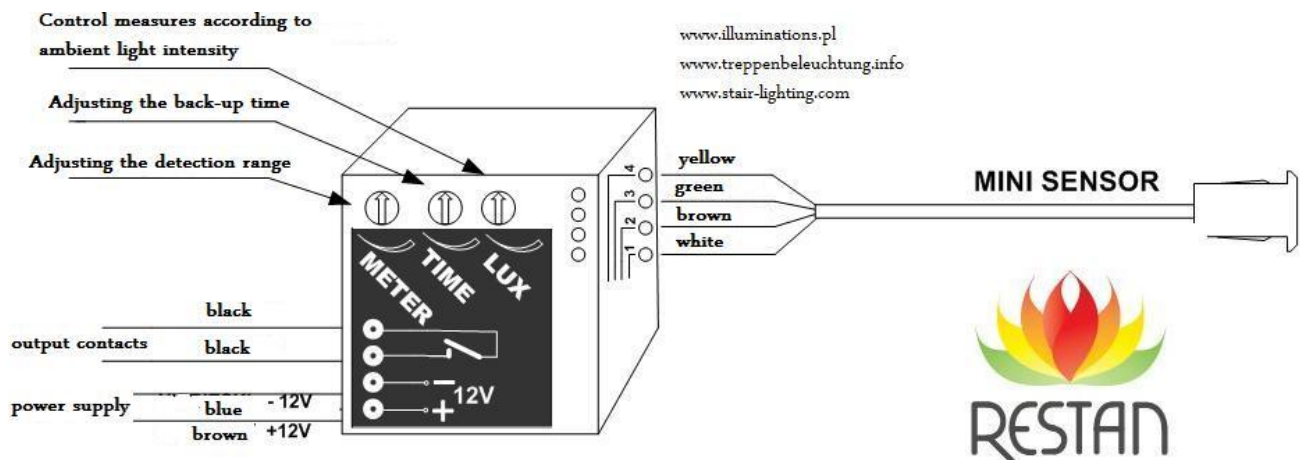

Install a mini sensor - connect "only" wire:

- in 1 - White
- in 2 - Brown
- In 3 - Green

Potentiometer - **METER** - set the max distance from the sensor for motion detection

Potentiometer - **TIME** - set-up time relay (for controllers stair set at minimum)

Then connect the wire

- In 4 – yellow - and set potentiometer - **LUX** - a threshold value depending on the ambient light intensity.

